



Department of Computer Science
Faculty of Computing
UNIVERSITI TEKNOLOGI MALAYSIA

SUBJECT : SCSR1013 DIGITAL LOGIC

SESSION/SEM : 2020/2021/01

**LAB 2 : COMBINATIONAL LOGIC CIRCUIT DESIGN
SIMULATION**

NAME 1 : Chong Kah Wei A20EC0027

NAME 2 : Heong Yi Qing A20EC0043

DATE : 20.01.2021

REMARKS :

MARKS:

Lab # 2

Combinational Digital Circuit Design Simulation Using Deeds Simulator

A. Objective

- i) To expose student with producing digital logic circuit, generating truth table and Timing Diagram with Deeds Simulator.
- ii) To expose student with a complete cycle process of a combinatorial circuit design and simulate with Deeds Simulator.

B. Material

Install Deeds Software for Windows.

C. Introduction

Deeds Simulator

The Digital Circuit Simulator *d-DcS* appears to the user as a graphical schematic editor, with a library of simplified logic components, specialized toward pedagogical needs and not describing specific commercial products. As described before, the schematic editor allows building a simple digital networks composed of gates, flip-flops, pre-defined combinational and sequential circuits and custom-defined components (defined as Finite state machine).

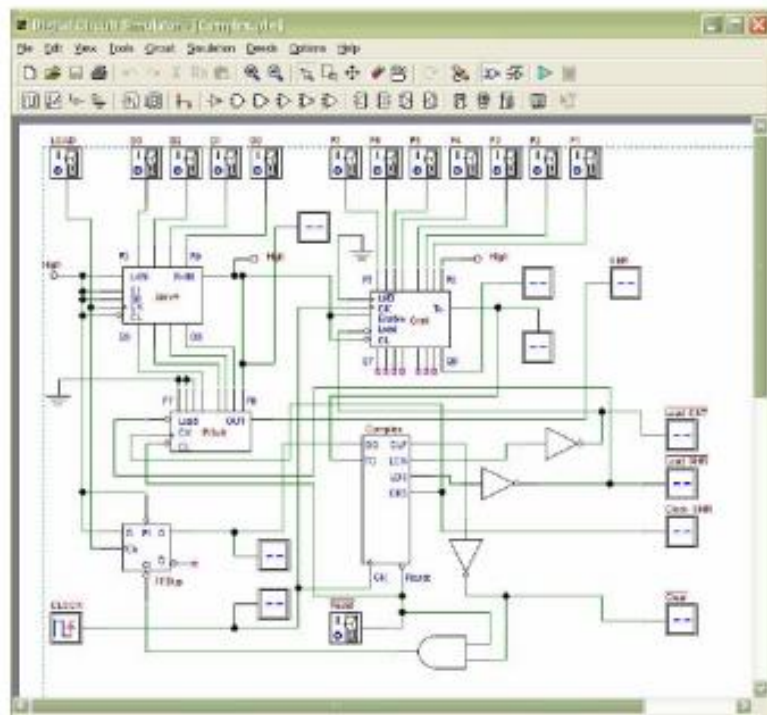

Figure 1 Circuit Editor of Digital Circuit Simulator (d-DcS)

Simulation can be interactive or in timing-mode. In **interactive mode**, the student can "animate" the digital system in the editor, controlling its inputs and observing the results. This is the simplest mode to examine a digital network, and this way of operation can be useful for the beginners. In **timing mode**, the behavior of the circuit can be analyzed by a timing diagram window, in which the user can define graphically an input signal sequence and observe the simulation results.

Digital Circuit Simulator (d-DcS): A Simple Example

In the following screen shots (Figure 2a, 2b, and 2c), student can see the circuit during the drawing and then simulate it by animation with following simple steps:

- a) student picks-up components from the *Component Tool Bar*.
- b) connects them using *Wires*.
- c) student activates the animation.

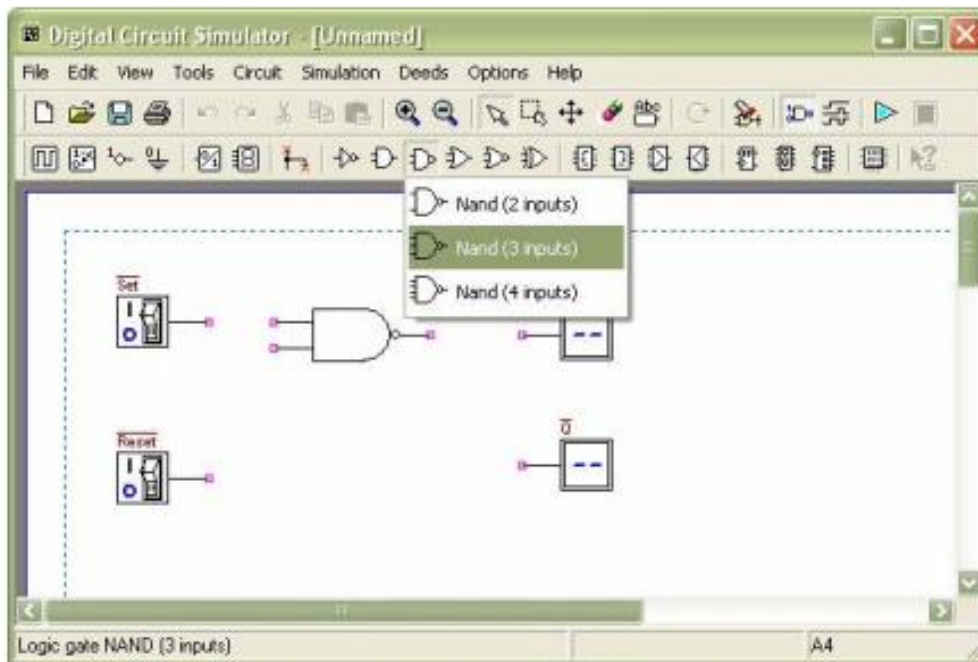

Figure 2a Drawing Phase of the Digital Circuit Editor: Insertion of Components

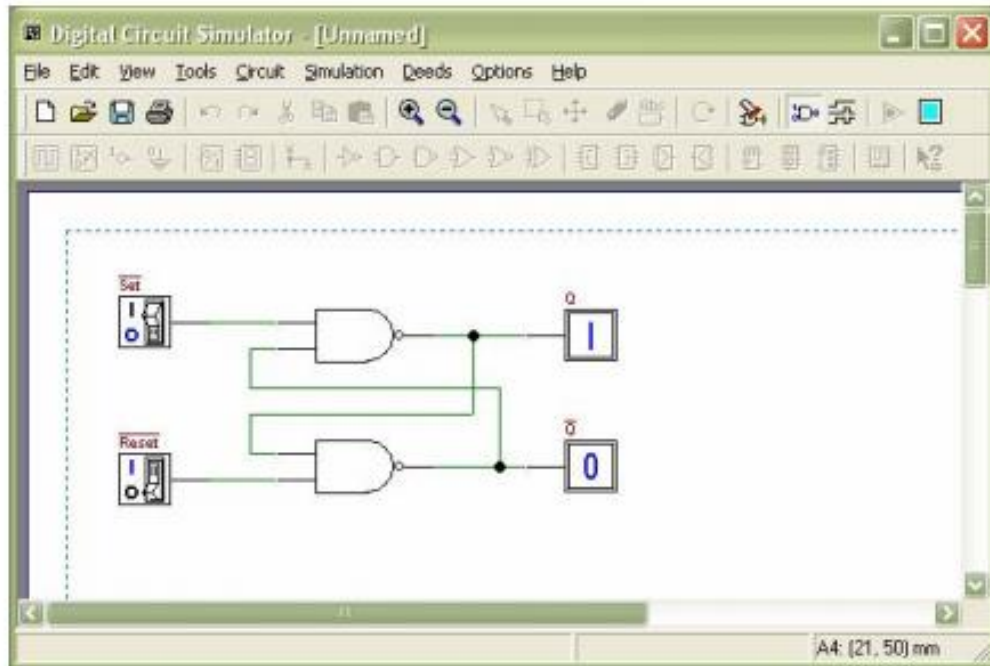

Figure 2b Next Phase of the Work: Connection of Components using *Wires*

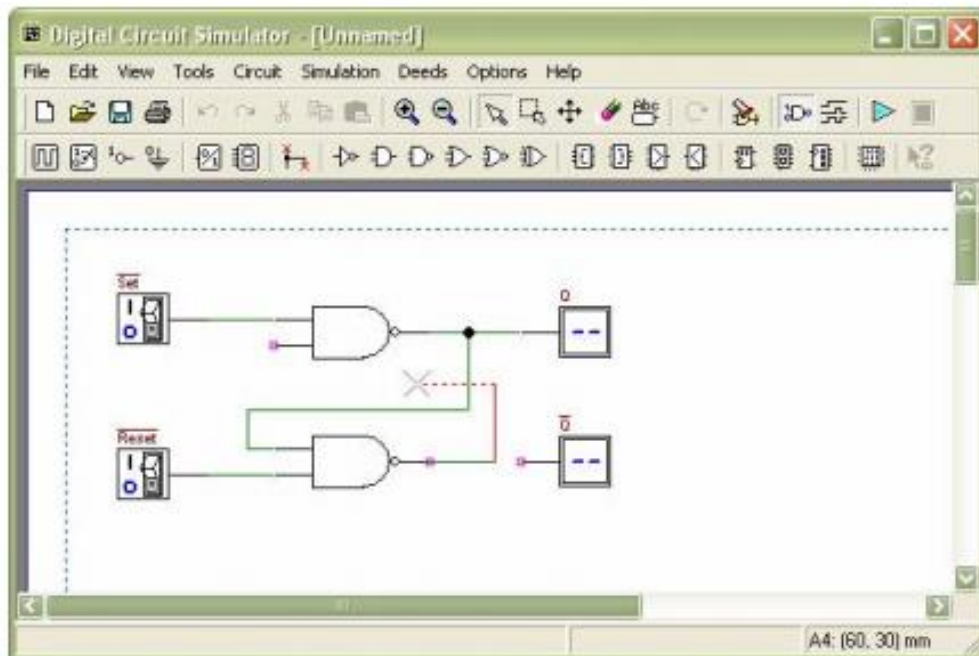

Figure 2c Animation: User Switches Inputs and the Circuit Shows Changes on Outputs

To exit the animation, it is necessary to click on the square *Stop* button. Instead, if the timing simulation is to be performed, student should click on the *Timing Simulation* button. This will show the Timing Diagram simulation window (Figure 3).

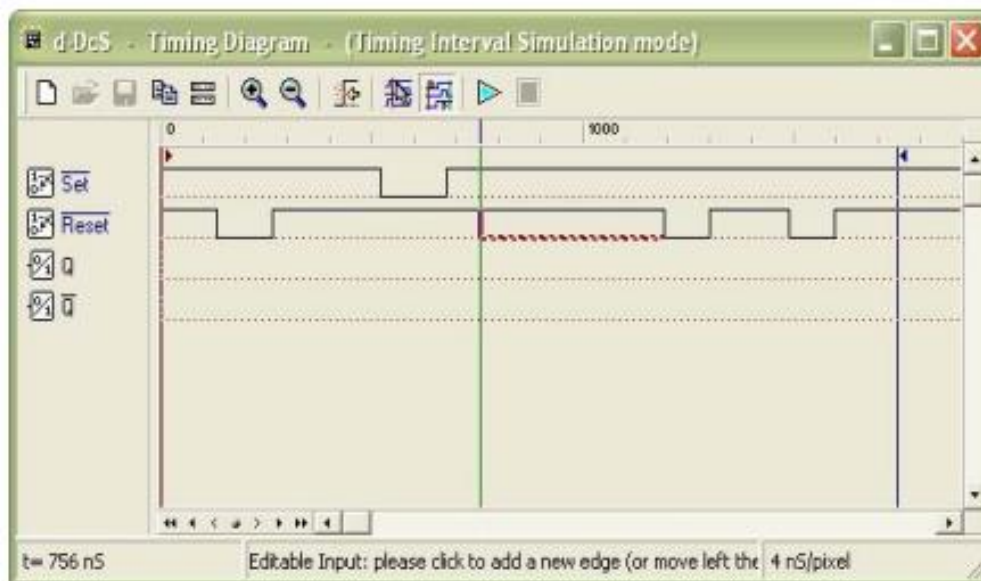

Figure 3 Timing Diagram Simulation Window

In this window, first student should define the timing of the input signals, drawing them on the diagram with the mouse. A vertical line cursor permits to define the 'end time' of the simulation. When student clicks on the triangular *play* button on the toolbar, the simulation is executed, and its results are displayed in the same window (Figure 4).

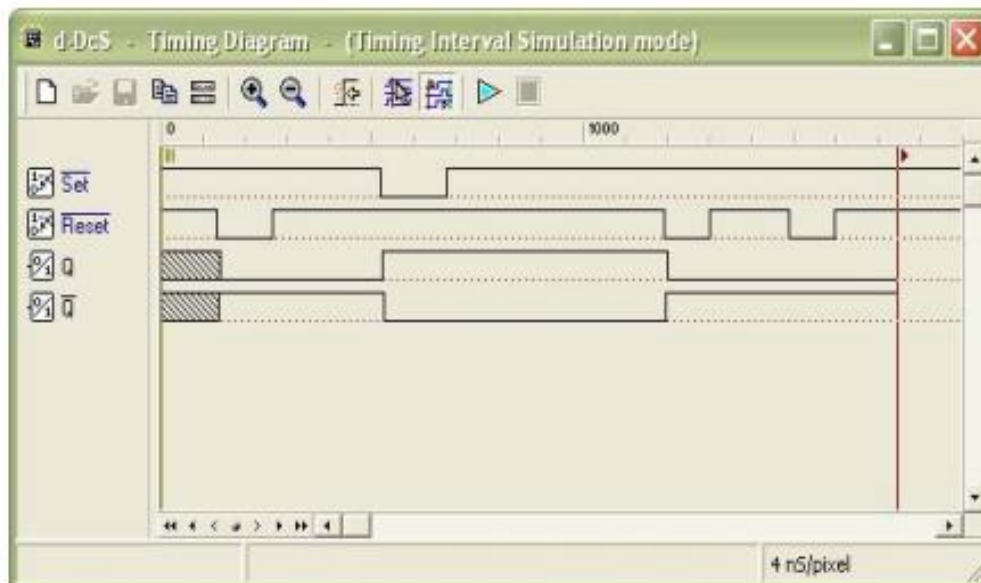

Figure 4 Timing Simulation Results, Displayed in Timing Diagram Window

Student can verify the correct behavior of the digital circuit, comparing simulation results with reasoning and theory concepts.

D. Lab Activities

Part 1

Simulating logic circuit, construct truth table and timing diagram with Deeds.

Given Boolean expression as follow:

$$Y = AB + BC + AC$$

1. Convert the non-standard Boolean expression into standard form.

$$Y = AB + BC + AC$$

$$Y = AB(C + \bar{C}) + BC(A + \bar{A}) + AC(B + \bar{B}) \quad \dots \text{using Rule 6}$$

$$Y = ABC + AB\bar{C} + ABC + \bar{A}BC + ABC + A\bar{B}C$$

$$Y = ABC + \bar{A}BC + A\bar{B}C + AB\bar{C}$$

2. Based on standard form expression, complete the following truth table.

INPUT			OUTPUT
A	B	C	Y
0	0	0	0
0	0	1	0
0	1	0	0
0	1	1	1
1	0	0	0
1	0	1	1
1	1	0	1
1	1	1	1

3. Using Deeds Simulator, draw the following circuits:

a) Circuit (i) for non-standard form (based on the given expression).

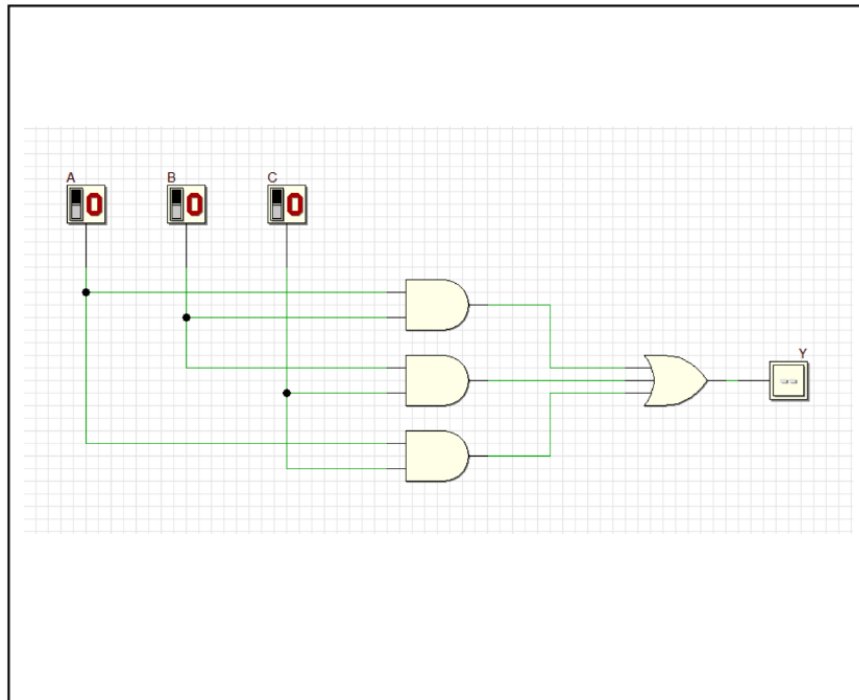

Circuit (i)

b) Circuit (ii) for standard form (from your answer in question (1)).

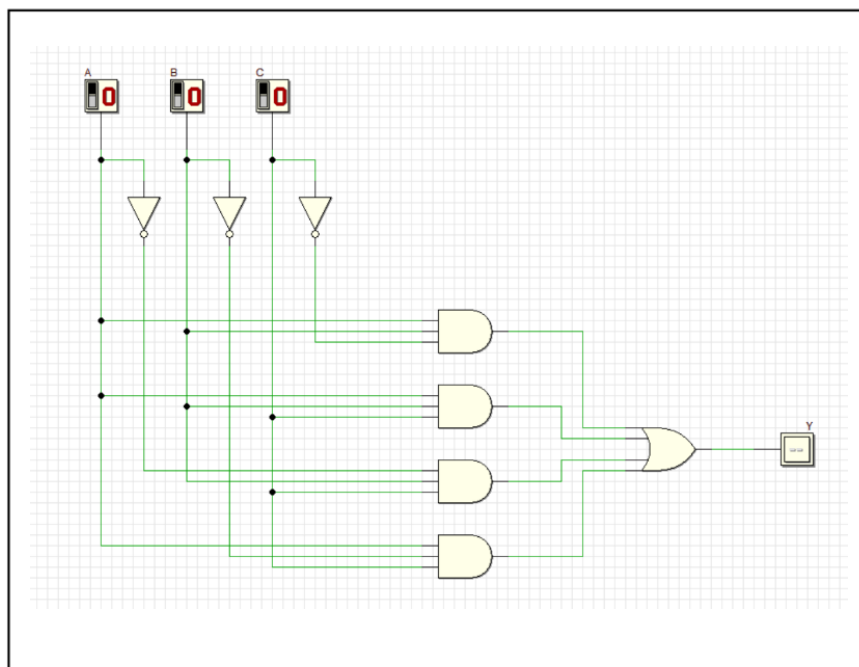

Circuit (ii)

4. Simulate these two circuits in step (3) and complete their truth table.

Compare the simulation result for these two truth tables. What is your conclusion?

Circuit (i)

INPUT			OUTPUT
A	B	C	Y
0	0	0	0
0	0	1	0
0	1	0	0
0	1	1	1
1	0	0	0
1	0	1	1
1	1	0	1
1	1	1	1

Circuit (ii)

INPUT			OUTPUT
A	B	C	Y
0	0	0	0
0	0	1	0
0	1	0	0
0	1	1	1
1	0	0	0
1	0	1	1
1	1	0	1
1	1	1	1

Conclusion:

Both circuits produce the same output. We can conclude that when non-standard Boolean expression is converted to standard form, they are still the same and will execute the same results.

5. Simulate output of circuit (ii) with Timing Diagram. Illustrate some examples of different inputs and output.

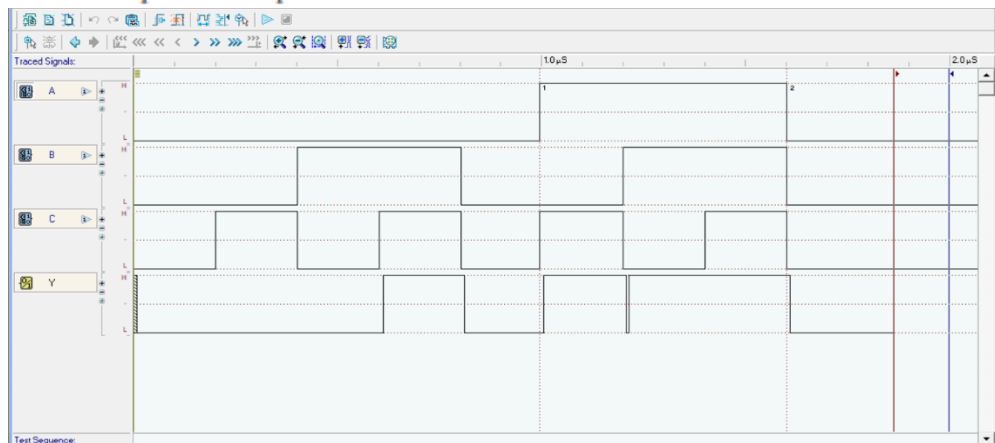

From the timing diagram, there must be at least two input are high only will produce an output results in high. Each input has a path which link to the inverter before into the and gate. We can see that the inputs to three of the AND gates are basically three direct and one inverted input. So, if two of the inputs are high, then one of the AND gates will receive two high inputs and an inverted low input will produce a high output. If any of the and gate get high output, the final output will be high as well.

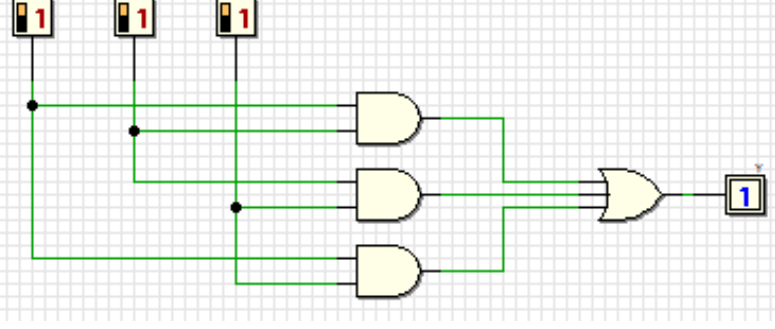
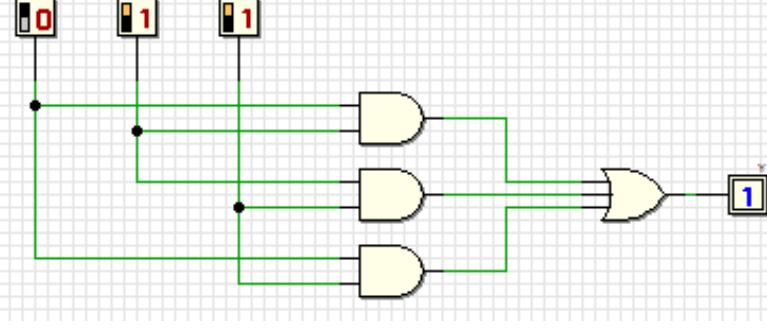
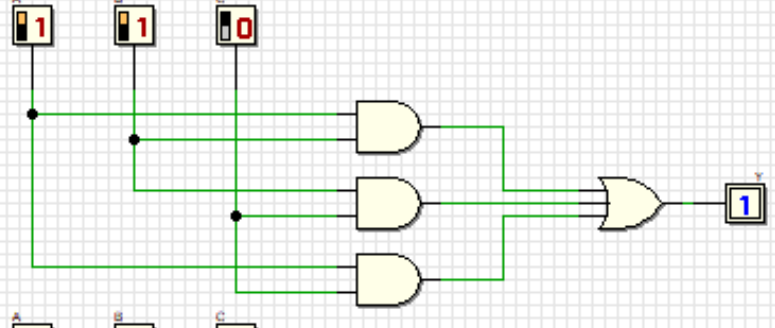
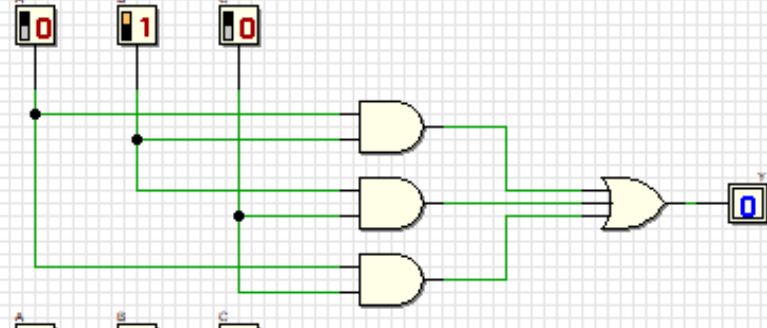
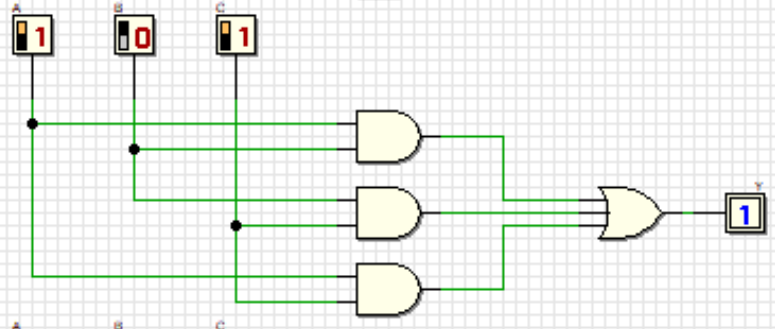
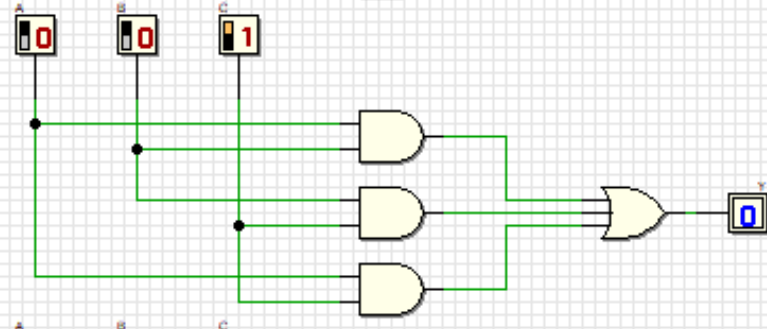
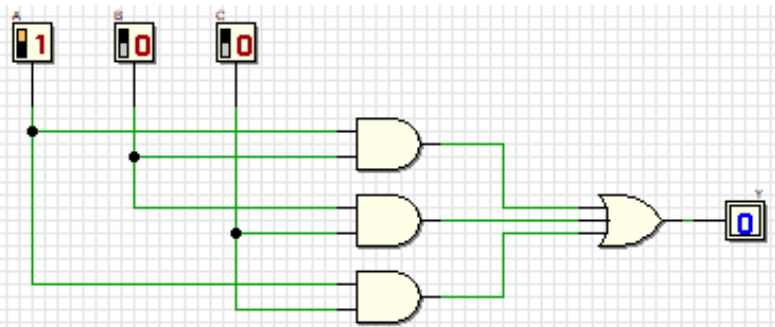
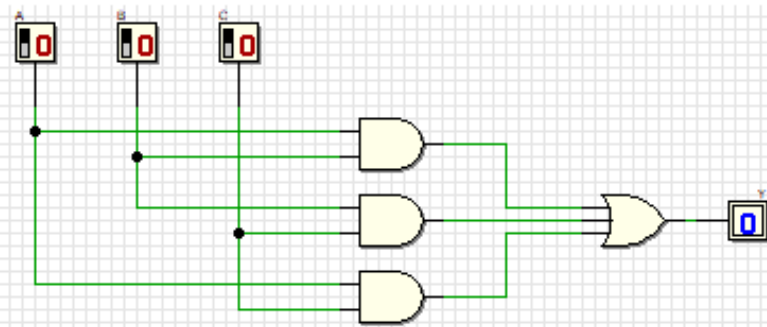

Part 2

Combinational circuit design process and simulate with Deeds Simulator.

Design Process

- i) Determine Parameter Input / Output and their relations.
- ii) Construct Truth Table.
- iii) Using K-Map, get the SOP optimized form of all Boolean equation outputs.
- iv) Draw the circuit and use duality symbol; convert AND-OR circuit to NAND gates ONLY.
- v) Simulate the design using Deeds Simulator. Check the results according to Truth Table and Timing Diagram Operation.

Problem Situation

A new digital fault diagnoses circuit is requested to be designed for analyzing four bit 2's complement input binary number from sensors A, B, C, and D. Sensor A represents input MSB and sensor D represents input LSB. As shown in the following Figure 5, bit pattern analysis from input sensors A, B, C, and D will trigger four different output errors (active HIGH) of type E1, E2, E3, and E4.

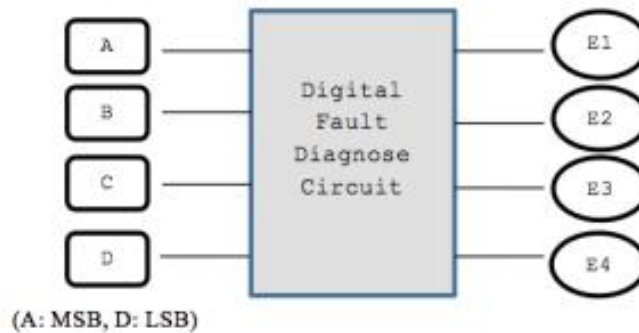

Figure 5

The following rules are used to activate the error's signal type:

- RULE 1:** E1 is activated if the input number is positive ODD and the majority of the bits is '0'.
 - RULE 2:** E2 is activated if the input number is positive EVEN and the majority of the bits is '0'.
 - RULE 3:** E3 is activated if the input number is negative ODD and the majority of the bits is '1'.
 - RULE 4:** E4 is activated if the input number is negative EVEN and the majority of the bits is '1'.
 - RULE 5:** The output of error signal is invalid if the input has equal bit '0' and bit '1'.
- (NOTE:** Positive ODD is positive numbers that are odd and negative EVEN is negative numbers that are even).

Experimental Steps

1. Complete Truth Table 1 for Digital Fault Diagnose Circuit. Use variables A, B, C and D as inputs; E1, E2, E3 and E4 as outputs.

Truth Table 1

INPUTS				OUTPUTS			
A	B	C	D	E1	E2	E3	E4
0	0	0	0	0	1	0	0
0	0	0	1	1	0	0	0
0	0	1	0	0	1	0	0
0	0	1	1	X	X	X	X
0	1	0	0	0	1	0	0
0	1	0	1	X	X	X	X
0	1	1	0	X	X	X	X
0	1	1	1	0	0	0	0
1	0	0	0	0	0	0	0
1	0	0	1	X	X	X	X
1	0	1	0	X	X	X	X
1	0	1	1	0	0	1	0
1	1	0	0	X	X	X	X
1	1	0	1	0	0	1	0
1	1	1	0	0	0	0	1
1	1	1	1	0	0	1	0

2. Using K-MAP, get minimized SOP Boolean expressions for E1, E2, E3 and E4 circuits.

	CD	00	01	11	10
AB	00	0	1	X	0
	01	0	X	0	X
	11	X	0	0	0
	10	0	X	0	X

$$E1 = \bar{A}BD$$

	CD	00	01	11	10
AB	00	1	0	X	1
	01	1	X	0	X
	11	X	0	0	0
	10	0	X	0	X

$$E2 = \bar{A}\bar{D}$$

	CD	00	01	11	10
AB	00	0	0	X	0
	01	0	X	0	X
	11	X	1	1	0
	10	0	X	1	X

$$E3 = AD$$

	CD	00	01	11	10
AB	00	0	0	X	0
	01	0	X	0	X
	11	X	0	0	1
	10	0	X	0	X

$$E4 = ACD$$

3. From the Boolean expression in the step (2), draw your final E1, E2, E3 and E4 circuits using 2 input basic gates (AND, OR, NOT). Use Deeds Simulator.

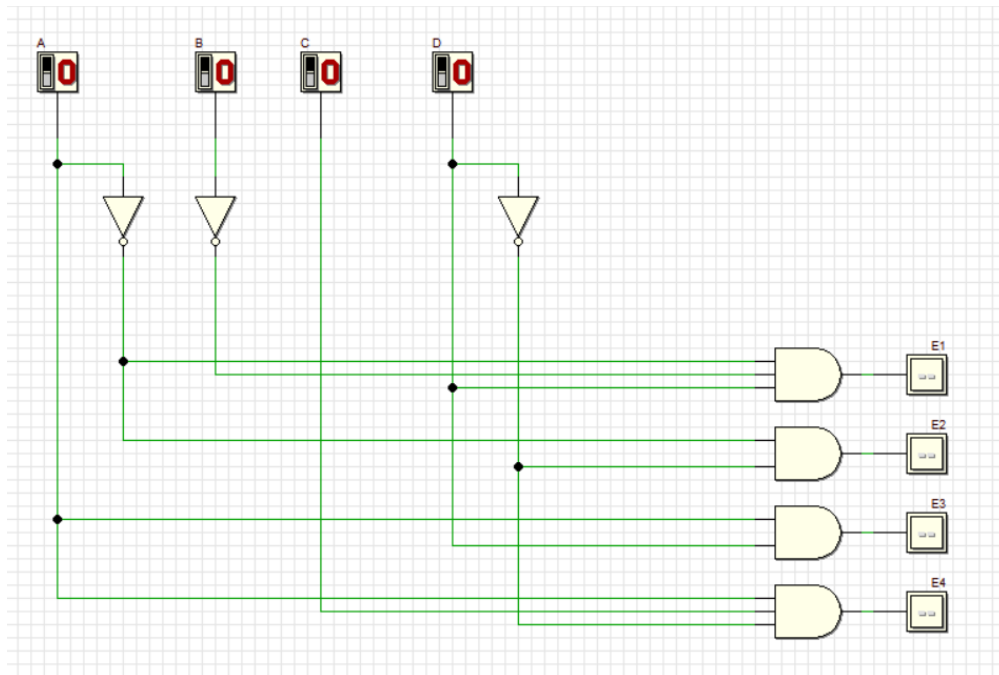

4. Simulate the Deeds circuit in step (3):

a) Update Truth Table 2 based on the simulation result.

Truth Table 2

INPUTS				OUTPUTS			
A	B	C	D	E1	E2	E3	E4
0	0	0	0	0	1	0	0
0	0	0	1	1	0	0	0
0	0	1	0	0	1	0	0
0	0	1	1	1	0	0	0
0	1	0	0	0	1	0	0
0	1	0	1	0	0	0	0
0	1	1	0	0	1	0	0
0	1	1	1	0	0	0	0
1	0	0	0	0	0	0	0
1	0	0	1	0	0	1	0
1	0	1	0	0	0	0	1
1	0	1	1	0	0	1	0
1	1	0	0	0	0	0	0
1	1	0	1	0	0	1	0
1	1	1	0	0	0	0	1
1	1	1	1	0	0	1	0

Compare the output results in Truth Table 2 with Truth Table 1. What is your conclusion?

The output results in Truth Table 2 are different with Truth Table 1. The result of Truth Table 1 consists of 'don't care', X which some of them are then used for forming a larger group in the K-map. The output of Truth Table 2 is based on the stimulation of circuit in Step(3), which is formed from the results of K-map. Thus, we can conclude that when X is used in the grouping of K-map, it will be treated as '1' and the output will be '1' in the Truth Table 2, whereas for the X which are not used to form a larger group in K-map, it will be treated as '0' in Truth Table 2.

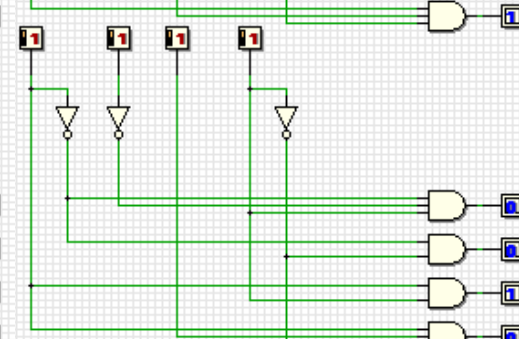
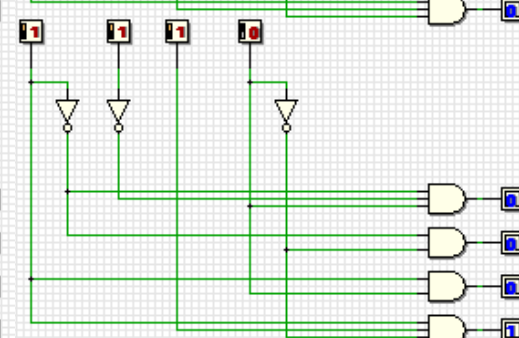
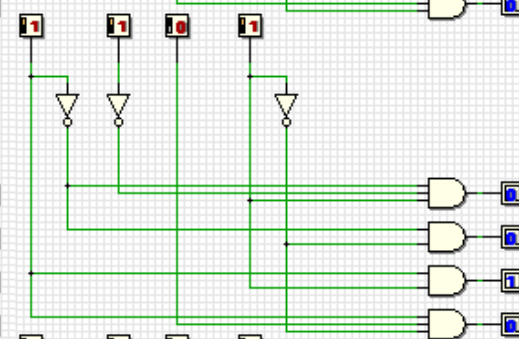
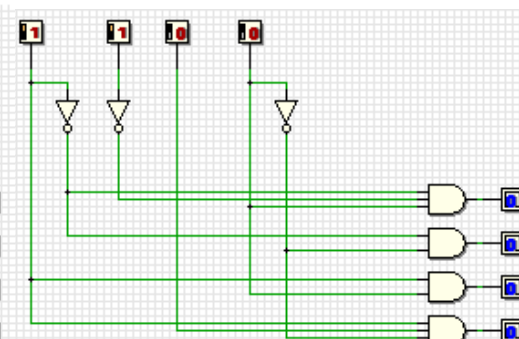
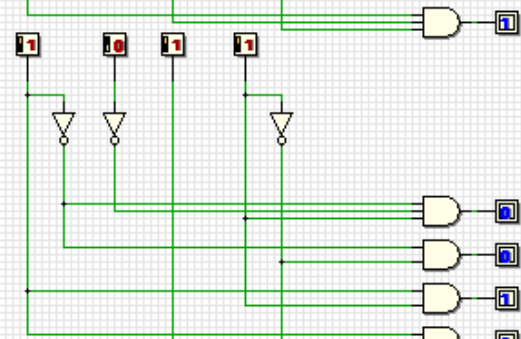
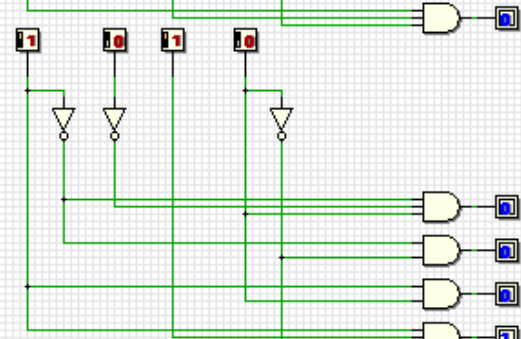
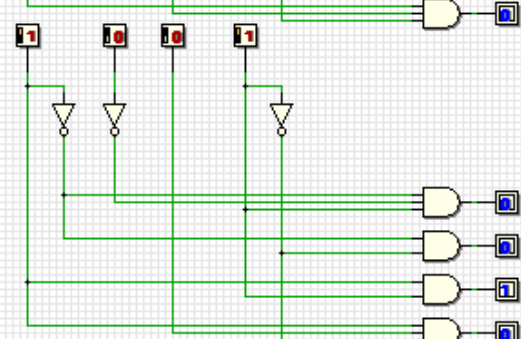
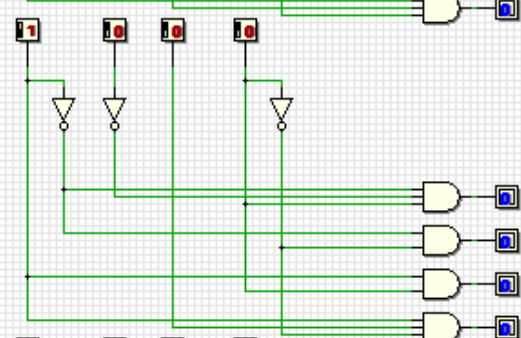
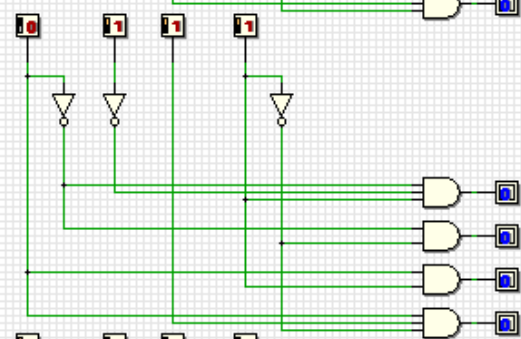
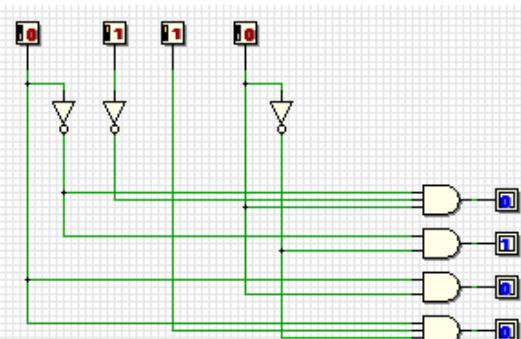
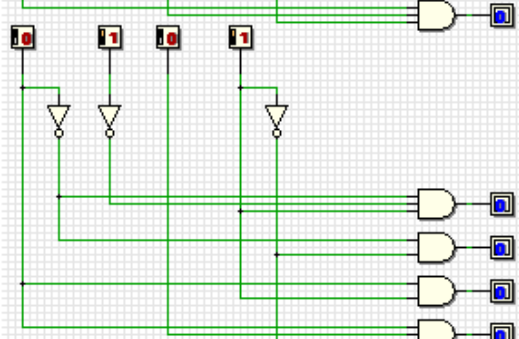
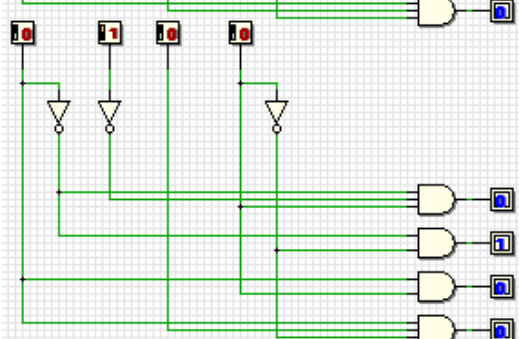
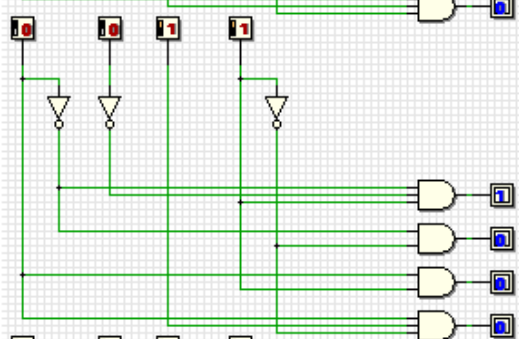
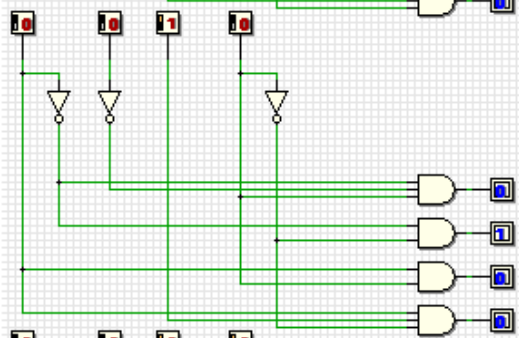
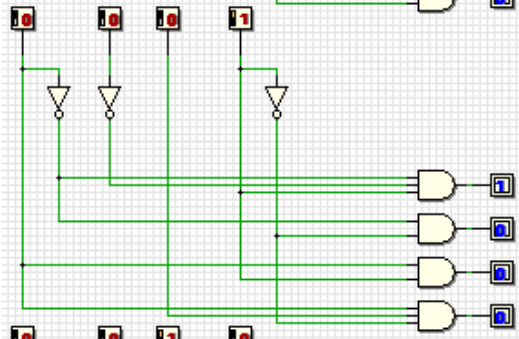
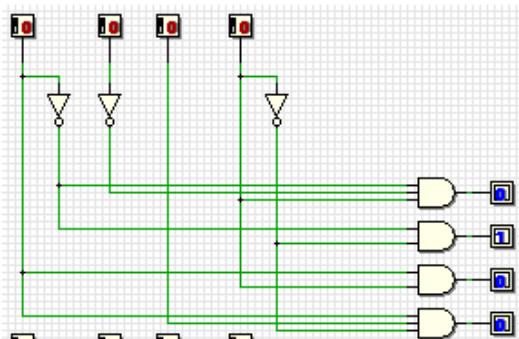

b) Timing Diagram

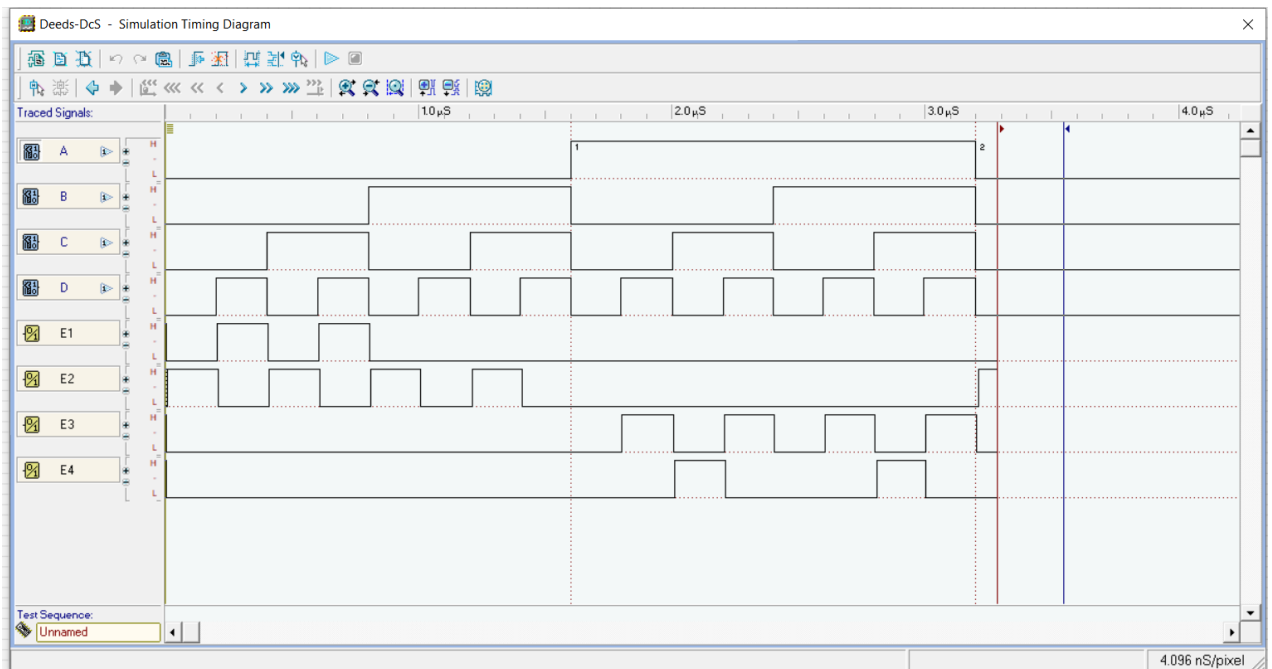

Explain some analysis values based on your timing diagram:

From the timing diagram, we can see that if input A and input B is low while input D is high, the output E1 will be high. When input A and input D is low, the output E2 will be high. On the other hand, when input A and input D is high, the output E3 will be high. Furthermore, when the input A and C is high while input D is low, the output E4 will be high. In conclusion, all of the inputs into the AND gate need to be high only the output results in high.

5. Using dual symbol concept, convert your circuit in step (3) to NAND gates only. Use Deeds Simulator.

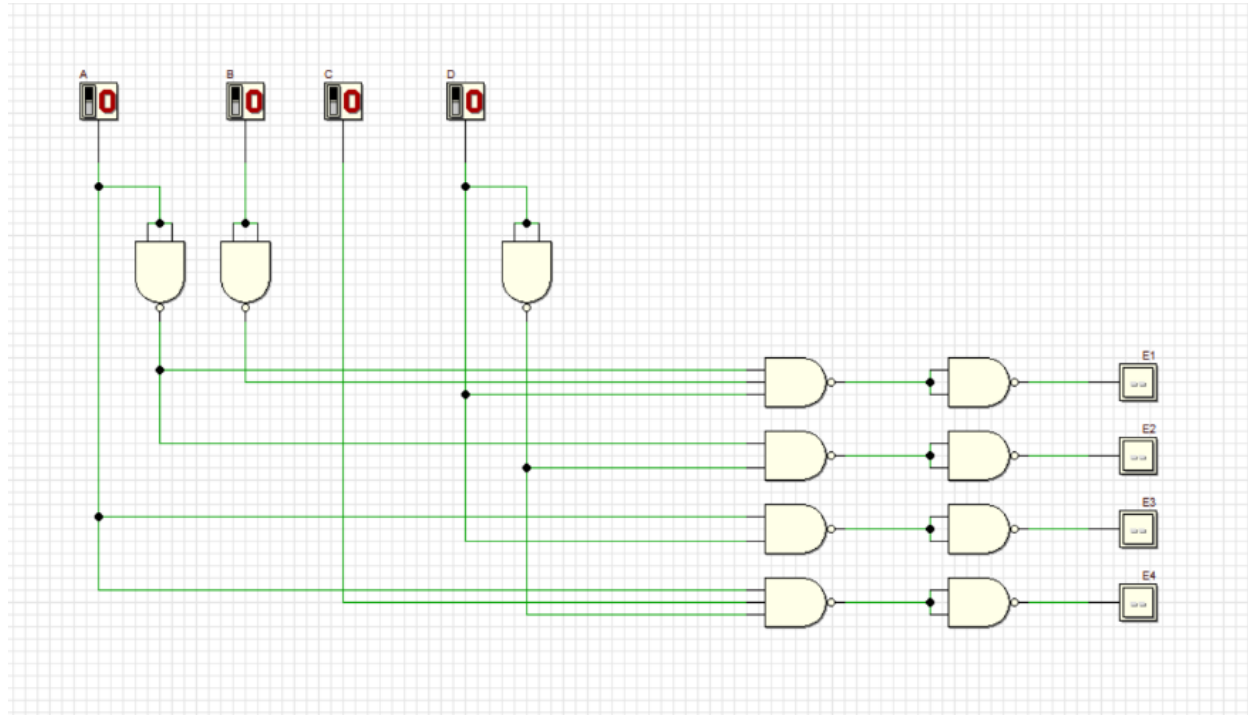

6. Simulate the Deeds circuit in step (5):

a) Update Truth Table 3 based on the simulation result.

Truth Table 3

INPUTS				OUTPUTS			
A	B	C	D	E1	E2	E3	E4
0	0	0	0	0	1	0	0
0	0	0	1	1	0	0	0
0	0	1	0	0	1	0	0
0	0	1	1	1	0	0	0
0	1	0	0	0	1	0	0
0	1	0	1	0	0	0	0
0	1	1	0	0	1	0	0
0	1	1	1	0	0	0	0
1	0	0	0	0	0	0	0
1	0	0	1	0	0	1	0
1	0	1	0	0	0	0	1
1	0	1	1	0	0	1	0
1	1	0	0	0	0	0	0
1	1	0	1	0	0	1	0
1	1	1	0	0	0	0	1
1	1	1	1	0	0	1	0

Compare the output results in Truth Table 3 with Truth Table 2. What is your conclusion?

Both output results in Truth Table 3 and Truth Table 2 are the same. In conclusion, NAND gate is a universal gate since it can perform as AND, OR and NOT gate.

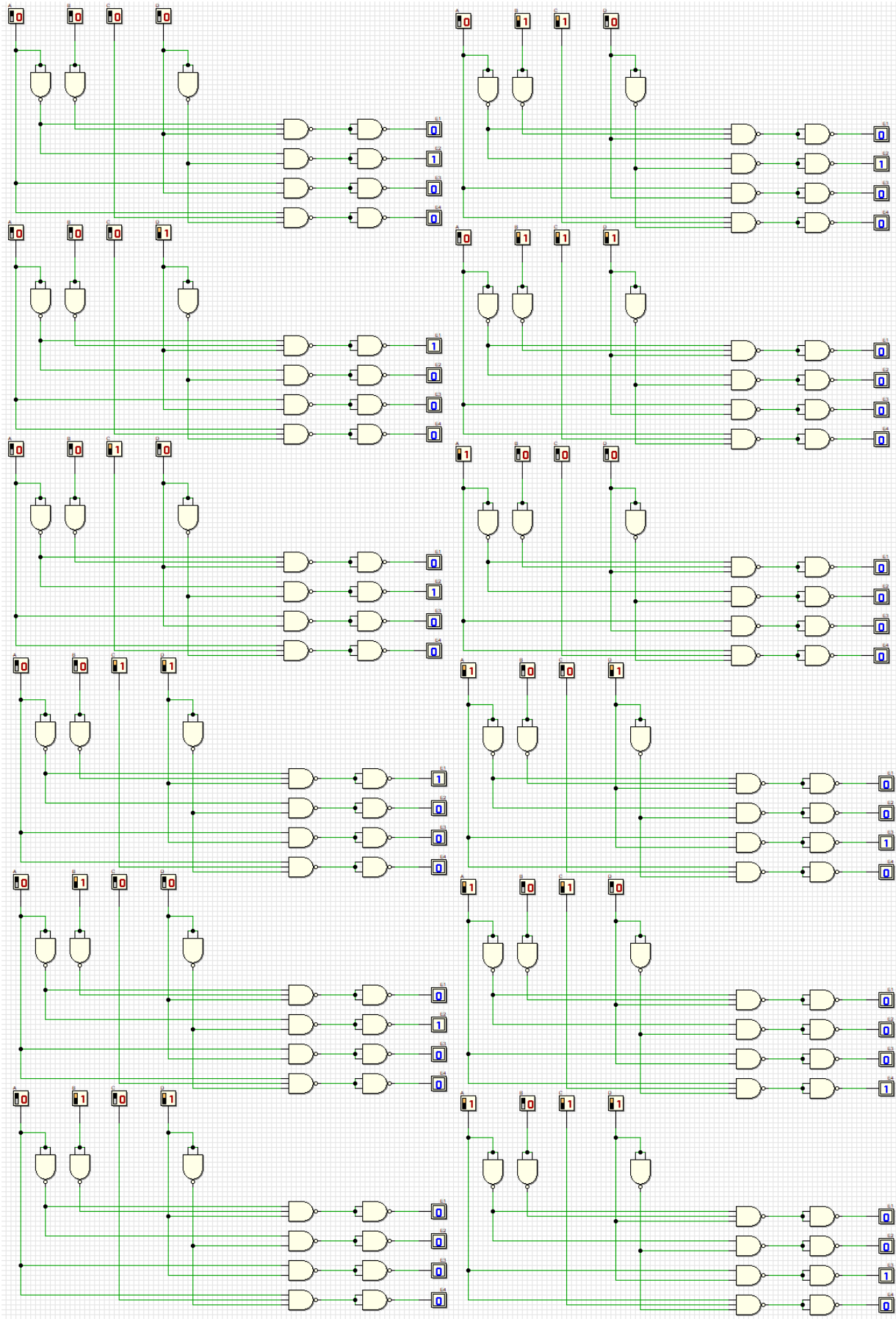

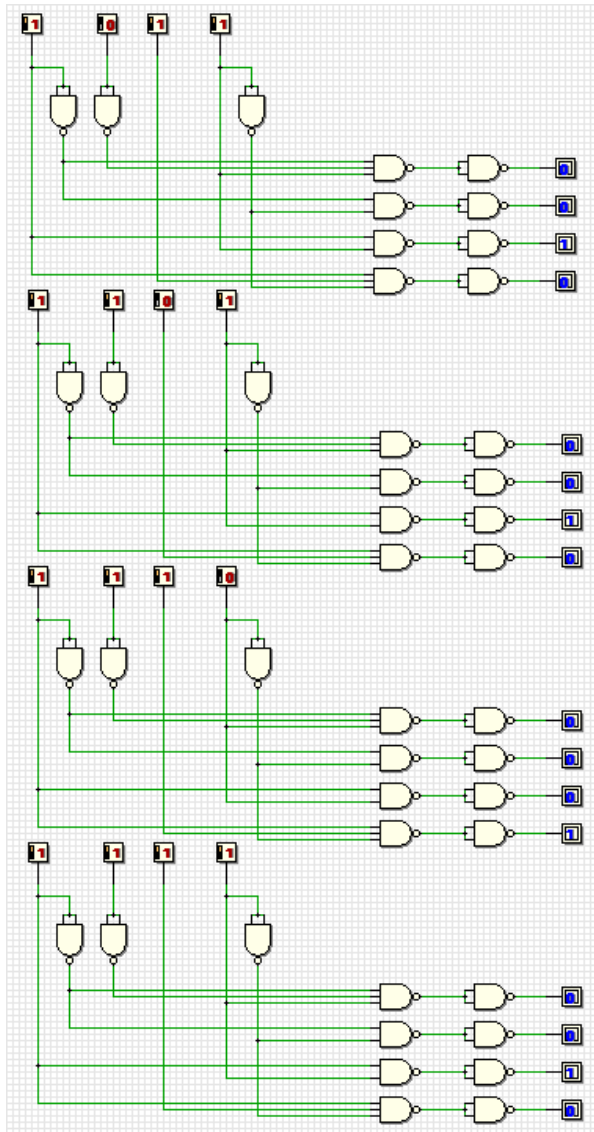

b) Timing Diagram

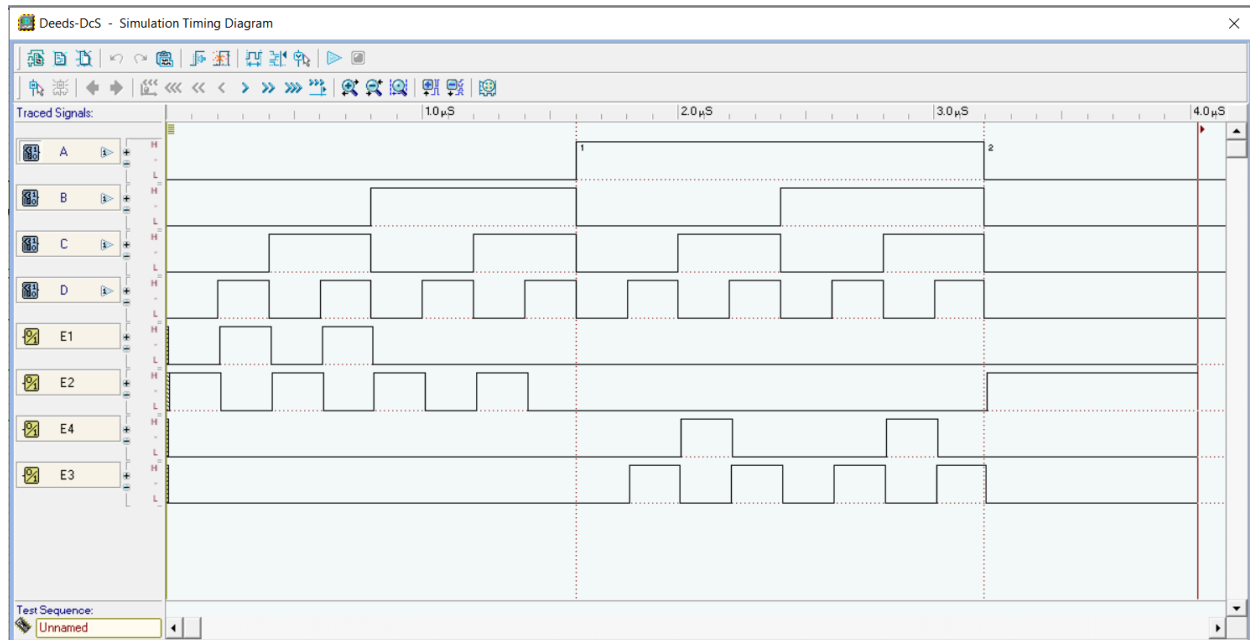

Explain some analysis values based on your timing diagram:

From the timing diagram, we can see that if input A and input B is low while input D is high, the output E1 will be high. When input A and input D is low, the output E2 will be high. On the other hand, when input A and input D is high, the output E3 will be high. Furthermore, when the input A and C is high while input D is low, the output E4 will be high. In conclusion, all of the inputs into the last two NAND gates need to be high only the output will be high, as two NAND gates can function as an AND gate.



Fully Completed

Partially Completed

Checked by: _____